

CTS - 90HLS

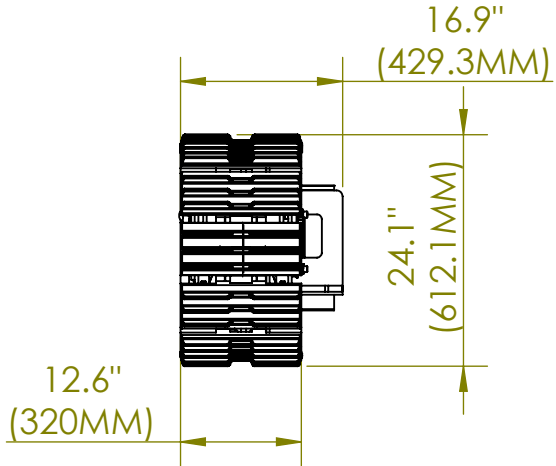
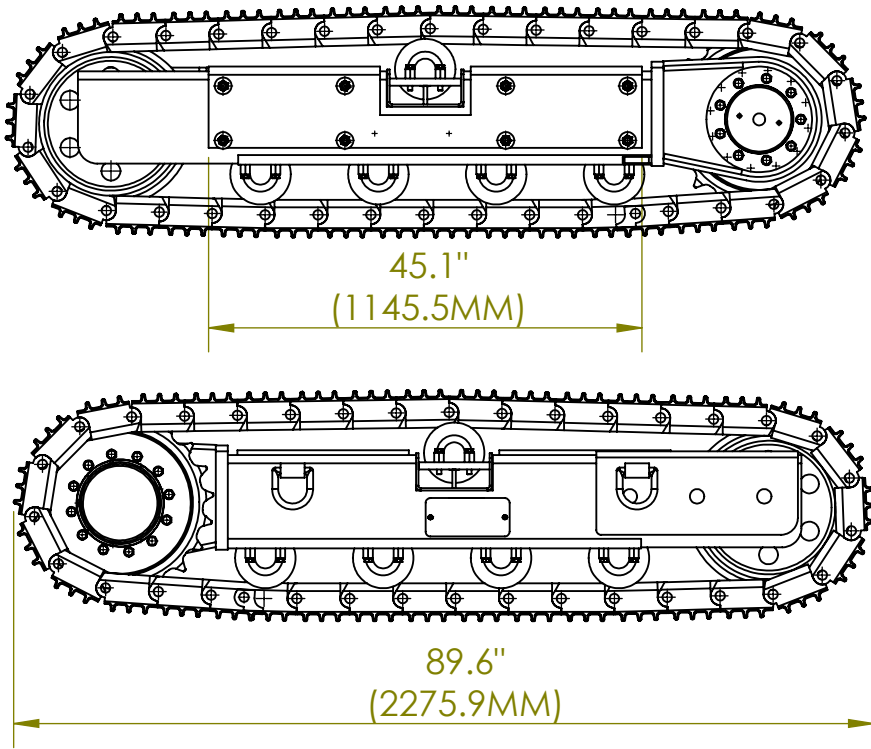

SPECIFICATIONS

MOTOR	OPEN LOOP	GPM PER MOTOR	GEAR RATIO	MAX GVW	MPH
HT 4B	2 SPEED / W BRAKE	20 @ 3500 PSI	58.4 : 1	15,000 LBS	L 1.34 / H 2.56
5B	2 SPEED / W BRAKE	21 @ 3500 PSI	64 : 1	25,000 LBS	L 1.54 / H 3.07